

# PIANO

Juan Francisco Carrillo Guzmán (2008)  
<http://masquepapel.blogspot.com/>

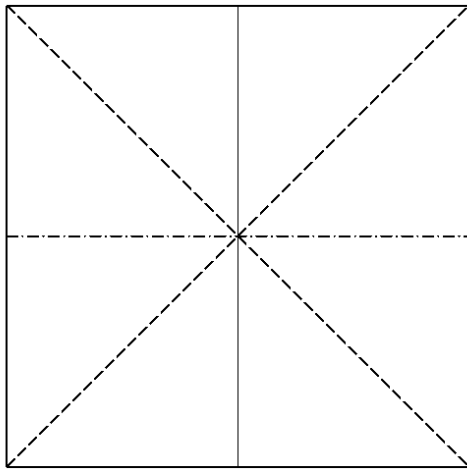

1. Plegar una base bomba



2.

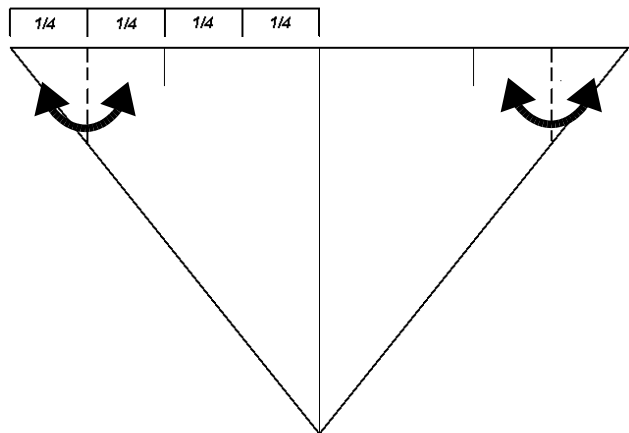

3. Usar como referencia el pliegue del paso 2.  
Desplegar la base

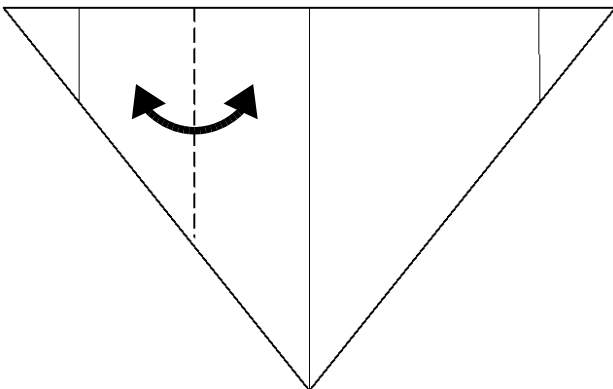

4. Tomar como referencia los pliegues del paso 2

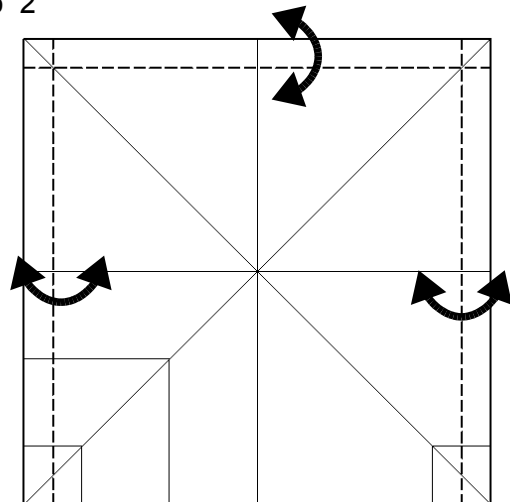

5. Doblar usando el pliegue formado en el paso 3

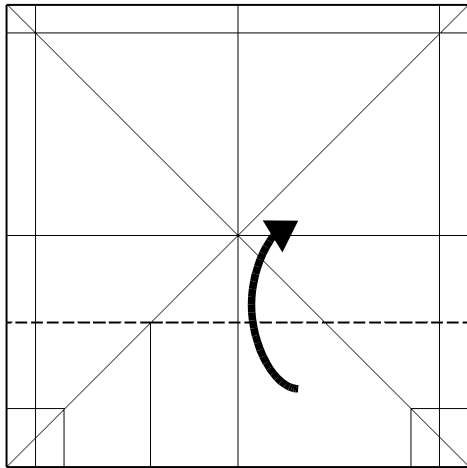

6. Marcar los pliegues y desdoblar el pliegue del paso 5.

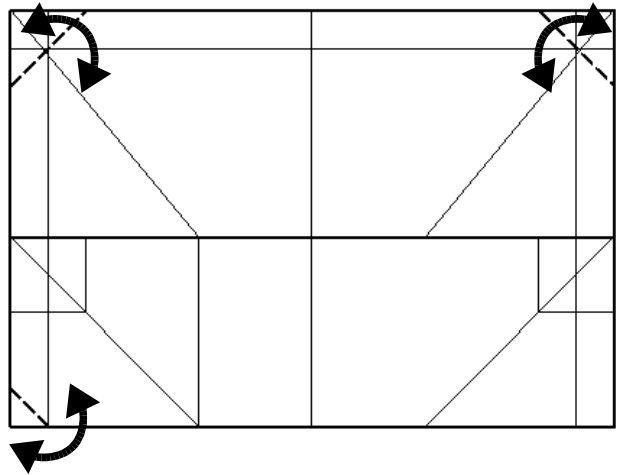

7.

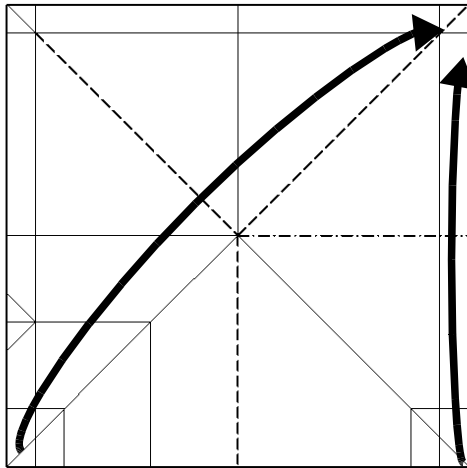

8.

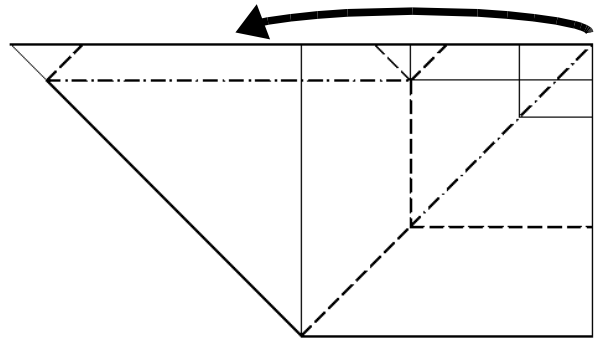

9. Dar la vuelta verticalmente

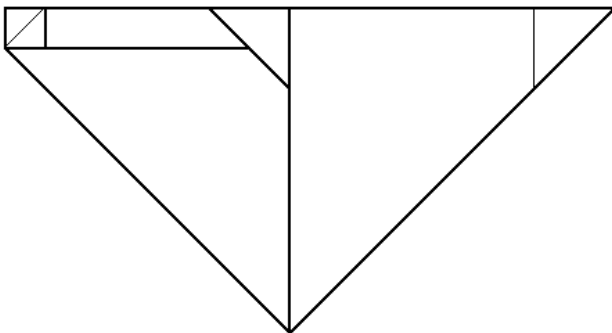

10.

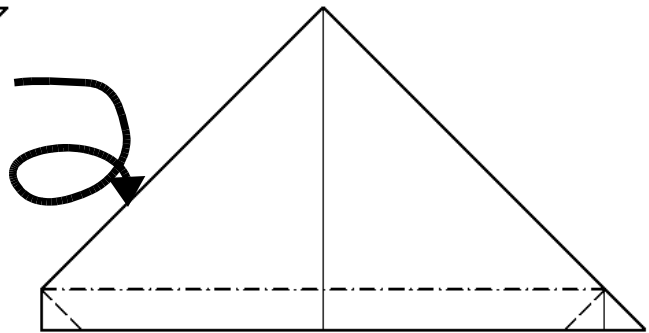

11.

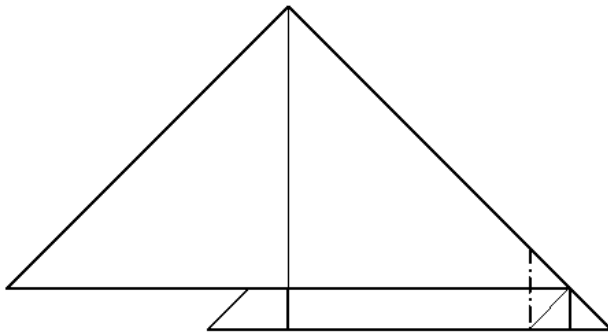

12. Hundir las puntas como se indica

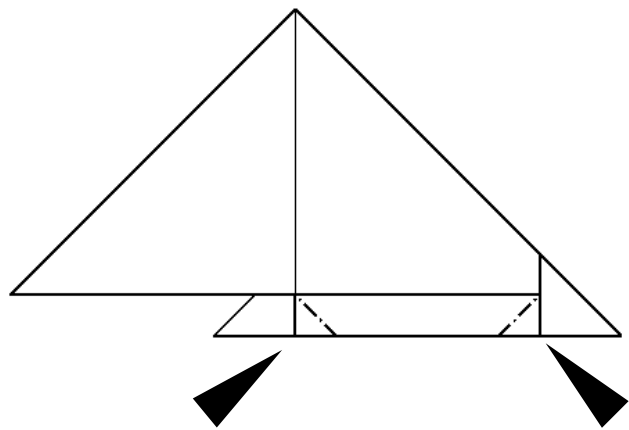

13. Cerrar la tapa del piano

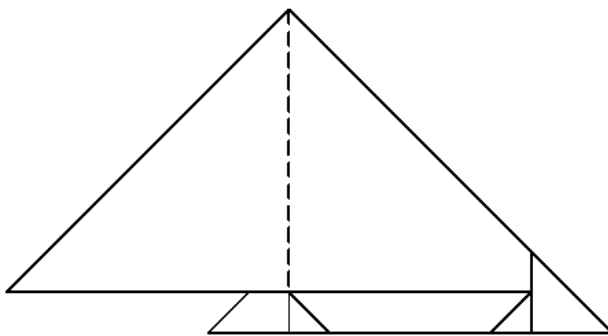

14. Hundir la punta de la tapa.

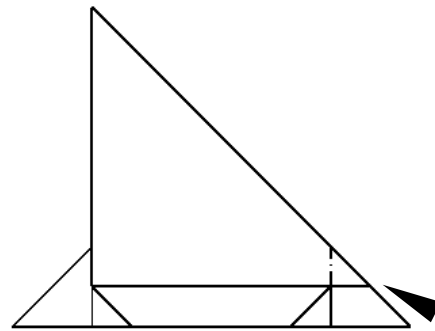

15. Plegar las patas y el atril del piano formando 90° con el resto del modelo.

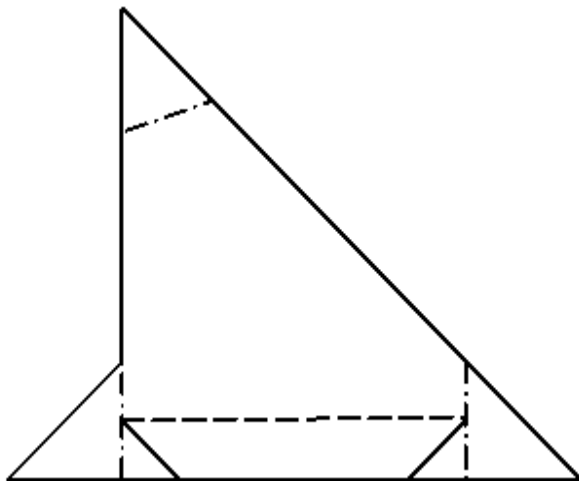

16. Abrir o cerrar la tapa para ajustar el sonido del piano.

